

# ENCORE<sup>®</sup> SERIES

## INSTALLATION AND OPERATING MANUAL

PN 99593

### SELF-SERVICE NON-REFRIGERATED BAKERY MERCHANDISER

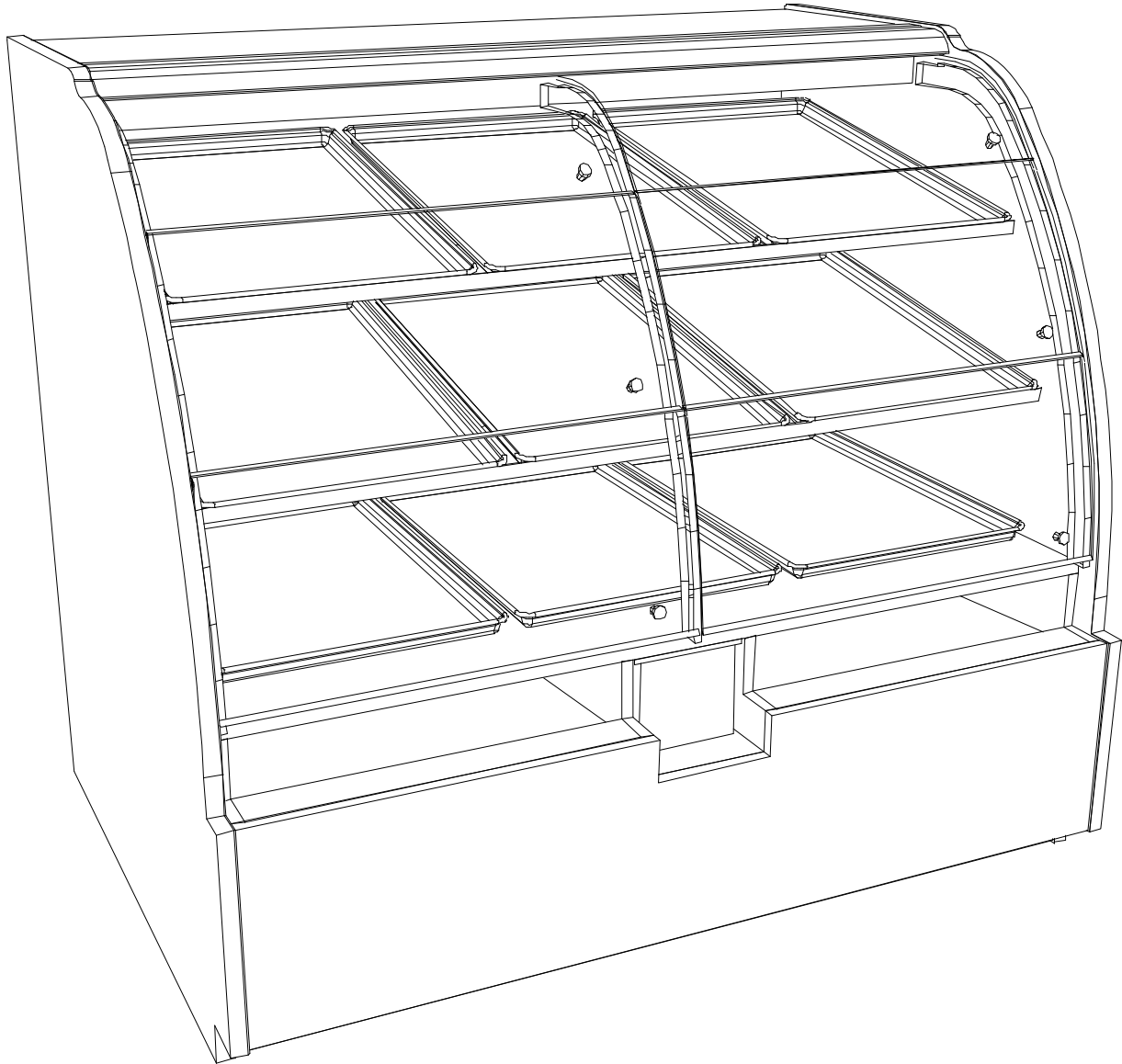

Model HVAD38SS.....38" L\* x 41" D x 51" H  
Model HVAD48SS.....50" L\* x 41" D x 51" H  
Model HVAD56SS.....58" L\* x 41" D x 51" H  
Model HVAD74SS.....76" L\* x 41" D x 51" H

*\*Without 1" end panels.*



888 E. Porter Road · Muskegon, MI 49441 Phone: 231.798.8888 Fax: 231.798.4960 [www.structuralconcepts.com](http://www.structuralconcepts.com)

## TABLE OF CONTENTS

OVERVIEW AND WARNINGS .....	3
INSTALLATION .....	4-5
START-UP AND OPERATION .....	6
MAINTENANCE FUNDAMENTALS.....	7
SERIAL LABEL & LOCATION / TECHNICAL INFORMATION / ADD'L INFORMATION .....	8
TROUBLESHOOTING .....	9
CLEANING SCHEDULE.....	10
TECHNICAL SERVICE CONTACT INFORMATION & WARRANTY INFORMATION .....	11

## OVERVIEW AND WARNINGS

### OVERVIEW

- The Structural Concepts Encore service non-refrigerated cases are designed to merchandise unpackaged bakery products at ambient temperatures.
- These cases should be installed and operated according to the following instructions to insure proper performance.
- This unit is designed for the display of products in ambient store conditions where temperatures and humidity are maintained at a maximum of 75° F and 55% relative humidity.



**ATTENTION INSTALLER**  
This equipment must be installed in compliance with all applicable NEC, federal, state and local codes.



**WARNING**  
Risk of Electric Shock.  
Disconnect Power Before Servicing Unit

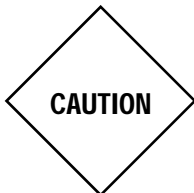

**CAUTION**  
Lamps have been treated to resist breakage and must be replaced with similarly treated lamps.

# INSTALLATION

## Installation

Note: Units shown may not depict an exact representation of your particular unit being installed.

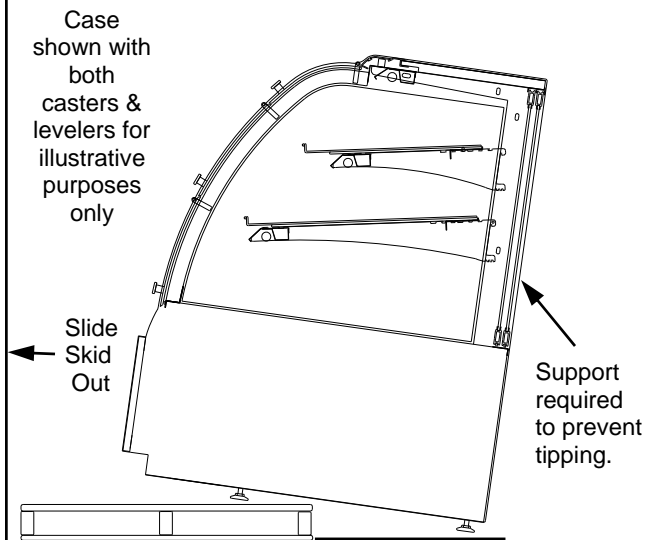

### **1. Remove Unit From Skid**

Caution: case must always remain supported or center of gravity will allow case to fall. Slide unit to rear of skid and tip backward off skid.

### **2. Position and Level Units**

Position Units. Align multiple units carefully in areas A, B, and C.

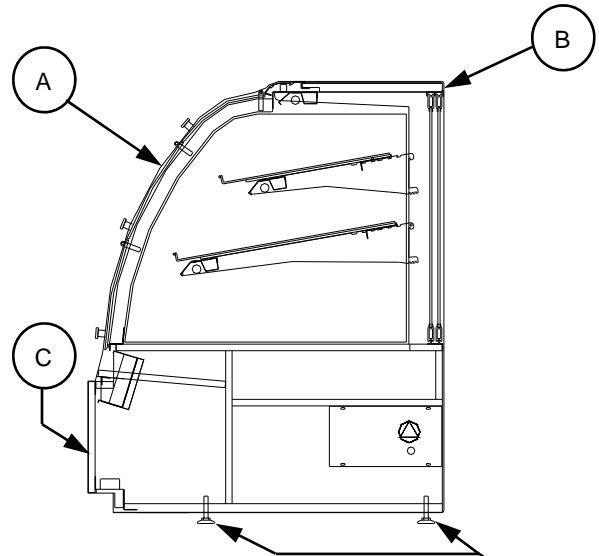

Adjustable Wrench



Leveler

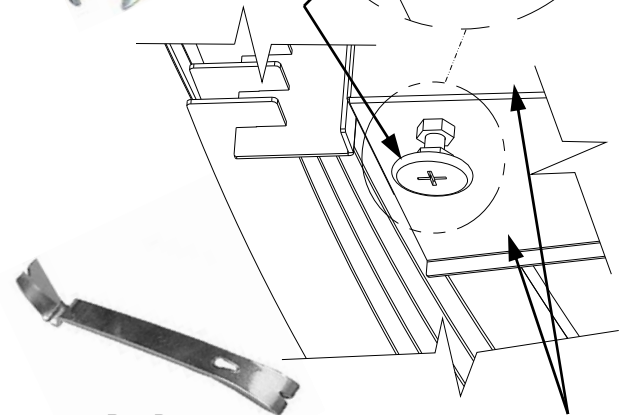

Pry Bar

Base

## Installation

Note: Units shown may not depict an exact representation of your particular unit being installed.

### 3. Bolting Adjoined Units

- View shown is after removal of end panel.
- Units are bolted together near locations shown.
- 1/4-20 x 2 1/2" nuts & bolts for locations 1-4.
- 1 1/2" long wood screws in random locations to be used for item 5.

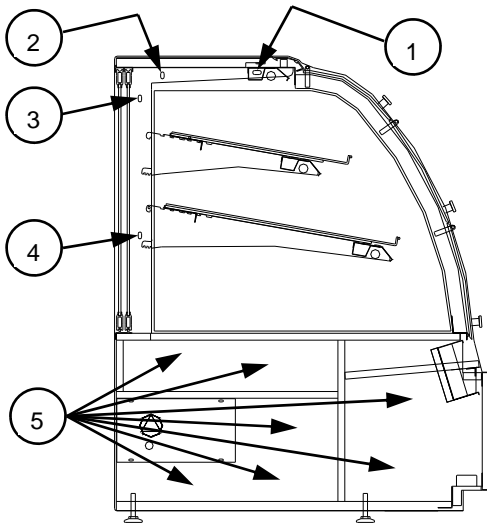

### 4. Electrical Connections

Field wiring hook-up / electrical access locations are shown in the plan view below.

- 120V single phase leads are provided.
- See Electrical Specifications Sheet for more detailed information.

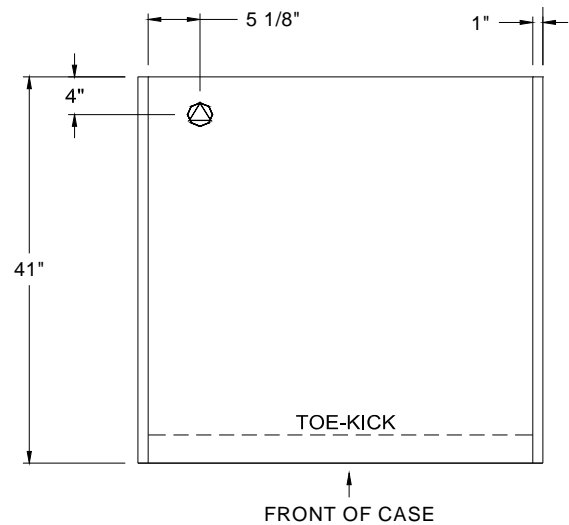

## START-UP AND OPERATION

### Merchandise Start-Up

- Turn on the lights. All of the lights should come on at the same time. First time lighting may require a short warm up period for the bulbs. Slightly dim or a flickering of new bulbs is normal.
- If lights do not turn on, check all of the raceway plugs. The lighting is wired in series so **all lights must be plugged in or receptacles capped** in order for the case to light.

### Raise the Curved Acrylic Doors

- To raise the curved acrylic doors, secure the lift handle extrusion on the bottom edge of the doors and lift up.
- **Caution:** Gently return doors to original positions. If doors are allowed to drop, they can injure fingers.

### Removing the Rear Doors

- See illustration at right.
- Move rear doors toward the center of case.
- Individually lift each door up toward top of case and pivot the bottom of the door out.
- **Caution:** Gently set doors down to avoid marring, scraping or breakage.

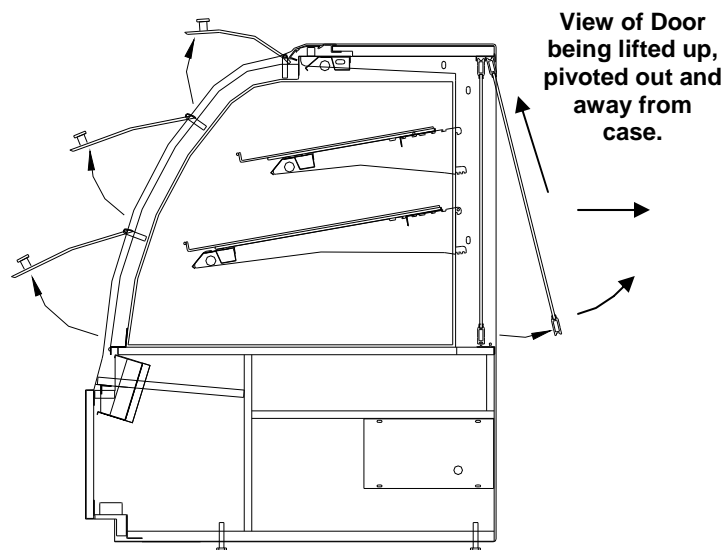
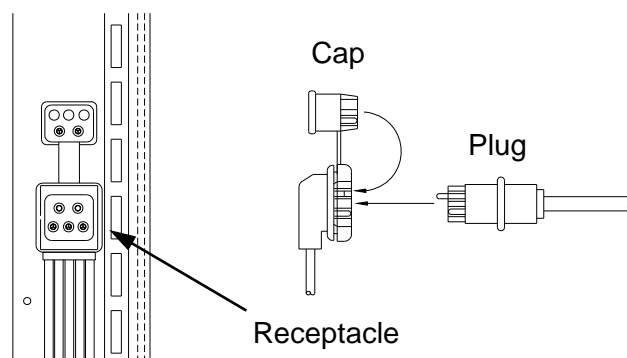
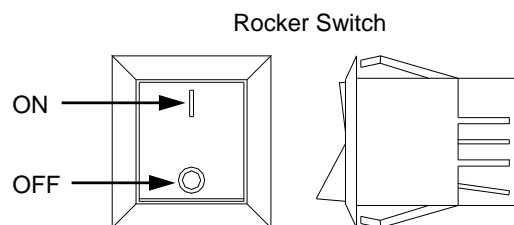

**Shelf Assembly Removal**

- Remove glass shelves
- For lighted shelving, unplug the light cord.
- Lift light shelf straight up to separate from brackets.
- Remove rear shelf support
- Remove brackets. Note it may be necessary to remove the nylon shipping bracket retainer. A pliers will be required to accomplish this task.

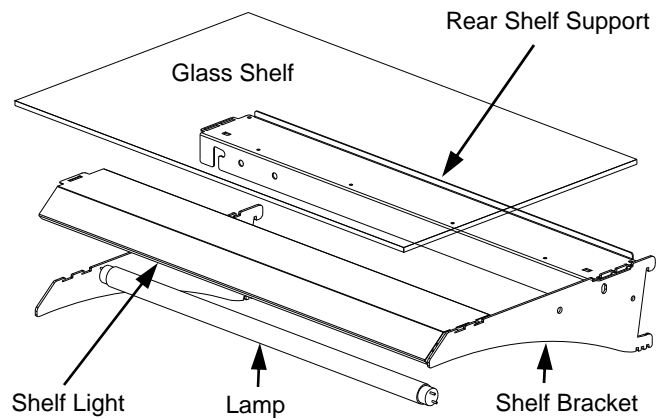

**Light Fixture**

Removal of lamp:

- Rotate lamp (1/4 turn) either direction to disengage (upper or lower) pins/contacts from lamp mounting sockets.
- Remove bulb by applying even pressure from the back side at the bulb ends and pulling the remaining contact from the sockets.

Installation of lamp:

- Align pins with slot.
- Insert pins into socket by rotating the bulb 1/4 turn to secure either the (upper or lower) pined contacts into the sockets.
- Rotate the remaining bulb contacts (1/4 turn) into the remaining lamp mounting socket contacts.

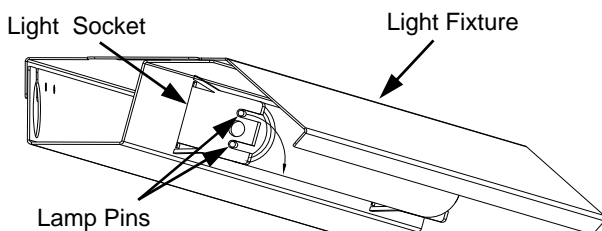
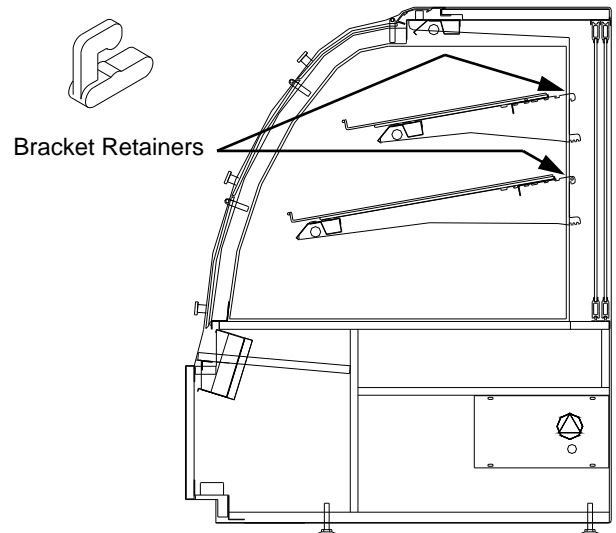

Above Photo Illustration shows Light Fixture. See illustrations at right for Lamp Removal Instructions.



Above Photo Illustrations show Lamp Removal. To Install, perform the above in reverse order.

**Serial Label Location & Information Listed / Technical Information & Service**

- Serial labels are located near the electrical access on your case.
- Serial labels contain electrical, temperature & refrigeration information, as well as regulatory standards to which the case conforms.
- For additional technical information and service, see the *TECHNICAL SERVICE* page in this manual for instructions on contacting Structural Concepts' Technical Service Department.
- See images below for samples of both refrigerated and non-refrigerated serial labels.



888 E. Porter Rd · Muskegon, MI 49441

**ENCORE<sup>®</sup>** MODEL HV74RSS SCROLL  
SERIES SERIAL NO.

**FOR PARTS AND SERVICE**  
CALL 1-800-433-9489



3048256  
CONFORMS TO UL STD 471  
CONFORMS TO NSF STD 7  
CERTIFIED TO CAN/CSA  
STD C22.2 NO 120

**ELECTRICAL RATING** 120/1/60 24A  
**REFRIGERANT** R404A AMOUNT ?? OZ  
**DESIGN PRESSURE** HIGH 450 LOW 200  
**MINIMUM CIRCUIT** 30A  
**MAXIMUM OVERCURRENT** 30A

SAMPLE ONLY

Super Heat Temp	8-10°F
BTUH Requirements	9,738 BTUH @ 20° F SST
Defrost	6 defrosts per day, 45° F termination, 45 min. failsafe

SAMPLE ONLY

----- Sample Serial Label For Refrigerated Case -----



888 E. Porter Rd · Muskegon, MI 49441

**Addenda<sup>®</sup>** PC5682 txtRemote  
txtSerialNumber

120 VOLTS 60 HZ SINGLE PHASE 1.84AMP

**FOR PARTS OR SERVICE CALL**  
**STRUCTURAL CONCEPTS**  
**AT**  
**1-800-433-9489**



3048256  
CONFORMS TO UL STD 65  
CERTIFIED TO CAN/CSA  
STD C22.2 NO 120

SAMPLE ONLY

N/A

----- Sample Serial Label For Non-Refrigerated Case -----

## TROUBLESHOOTING

<b>Product is Drying Out</b>	Check the relative humidity in the store.
<b>Doors/Glass Won't Shut Properly</b>	Check the case is aligned, level and plumb.
<b>System is not Operating</b>	Confirm the utility power is on.
	Check the MAIN power switch is on.
	Check the circuit breaker box for tripped circuits.
	If used, check the unit is properly plugged in.
<b>Case Lights Not Working</b>	Be sure <b>ALL</b> lights are plugged in or receptacles capped.
	Check bulb for proper installation and connection.
	Check for burned out bulb.
	Clean dirt and dust from the bulbs to prevent flickering.
	After performing all other checkpoints and lights are still not working Check for faulty ballast , this should be performed by a certified electrician.

## CLEANING SCHEDULE

Cleaning	Daily	Weekly	Monthly	Task
Clean Case Exterior	X			The acrylic must be cleaned with a mild soap and water solution and a soft cloth. <b>Never use a household cleaner on acrylic.</b>
	X			Clean sides and top of case with a warm soap and water solution.
Clean Case Interior	X			Clean glass shelves and mirrors with a household or commercial glass cleaner. The deck can be cleaned with a warm soap and water solution.
		X		Remove the deck and clean with soap and water.
		X		Remove rear doors and clean with a household or commercial cleaner (service cases only).
			X	<b>Warning: lowering the front glass doors with items inside top cap can cause serious injury or damage to case.</b> Raise the front curved glass doors. Clean inside the cavity at both ends of the hinged top cap with a mild soap and water.

STRUCTURAL CONCEPTS CORPORATION TECHNICAL SERVICE  
PHONE NUMBER: 1.800.433.9489 or For Your Master Service Agent See  
WWW.STRUCTURALCONCEPTS.COM/Contact/Master\_Service\_Agents.asp

## WARRANTY INFORMATION

**(Note: Standard Limited Warranty can be found at [www.Structuralconcepts.com](http://www.Structuralconcepts.com))**

All sales by Structural Concepts Corporation (SCC) are subject to the following limited warranty. "Goods" refers to the product or products being sold by SCC.

**Warranty Scope:** Warranty is for equipment sold in the United States, Canada, Mexico and Puerto Rico. Equipment sold elsewhere may carry modified warranty.

**Warranty; Remedies; Limitations.** SCC warrants that if any Goods are found by an authorized representative of SCC not to be of good material or workmanship within one year of the date of shipments SCC will, at its option after inspection by an authorized representative, replace any defective Good or pay the reasonable cost of replacement for any such defective Goods, provided that written notice of the defect is given to SCC within 30 days of the appearance of such defect. If notice is not given within such period, any claim for breach of warranty shall be conclusively deemed to have been waived and SCC shall not be liable under this warranty. If SCC is unable to repair or replace the defective Goods, SCC shall issue a credit to the Purchaser for all or part of the purchase price, as SCC shall determine. The replacement or payment in the manner described above shall be the sole and exclusive remedy of Purchaser for a breach of this warranty. If any Goods are defective or fail to conform to this warranty, SCC will furnish instructions for their disposition. No Goods shall be returned to SCC without its prior consent.

SCC's liability for any defect in the Goods shall not exceed the purchase price of the Goods. SCC SHALL HAVE NO LIABILITY TO PURCHASE FOR CONSEQUENTIAL DAMAGES OF ANY KIND WHATSOEVER, INCLUDING, BUT NOT LIMITED TO, PERSONAL INJURY, PROPERTY DAMAGE, LOST PROFITS, OR OTHER ECONOMIC INJURY DUE TO ANY DEFECT IN THE GOODS OR ANY BREACH OF SCC. SCC SHALL NOT BE LIABLE TO THE PURCHASER IN TORT FOR ANY NEGLIGENT DESIGN OR MANUFACTURE OF THE GOODS, OR FOR THE OMISSION OF ANY WARNING THEREFROM.

SCC shall have no obligation or liability under this warranty for claims arising from any other party's (including Purchaser's) negligence or misuse of the Goods or environmental conditions. This warranty does not apply to any claim or damage arising for or cause by improper storage, handling, installation, maintenance, or from fire, flood, accidents, structural defects, building settlement or movement, acts of God, or other causes beyond SCC's control.

Except as expressly stated herein, SCC makes no warranty, express, implied, statutory or otherwise as to any parts or goods not manufactured by SCC. SCC shall warrant such parts or Goods only (I) against such defects, (II) for such periods of time, and (III) with such remedies, as are expressly warranted by the manufacturer of such parts of Goods. Notwithstanding the foregoing, any warranty with respect to such parts of Goods and any remedies available as a result of a breach thereof shall be subject to all of the procedures, limitations, and exclusions set forth herein.

THE WARRANTIES HEREIN ARE IN LIEU OF ALL WARRANTIES, EXPRESS, IMPLIED, STATUTORY, OR OTHERWISE. IN PARTICULAR, SCC MAKES NO WARRANTY OF MERCHANTABILITY OR FITNESS FOR A PARTICULAR PURPOSE.

No representative, agent or dealer of SCC has authority to modify, expand, or extend this Warranty, to waive any of the limitations or exclusions, or to make any different or additional warranties with respect to Goods.

**Period of Limitations.** No claim, suit or other proceeding may be brought by Purchaser for any breach of the foregoing warranty or this Agreement by SCC or in any way arising out of this Agreement or relating to the Goods after one year from the date of the breach. In the interpretation of this limitation on action for a breach by SCC, it is expressly agreed that there are no warranties of future performance of the goods that would extend that period of limitation herein contained for bringing an action.

**Indemnifications.** Purchaser agrees to indemnify, hold harmless, and defend SCC if so requested, from any and all liabilities, as defined herein, suffered, or incurred by SCC as a result of, or in connection with, any act, omission, or use of the Goods by Purchaser, its employees or customers, or any breach of this Agreement by Purchaser. Liabilities shall include all costs, claims, damages, judgments, and expenses (including reasonable attorney fees and costs).

**Remedies of SCC.** SCC's rights and remedies shall be cumulative and may be exercised from time to time. In a proceeding or action relating to the breach of this Agreement by Purchaser, Purchaser shall reimburse SCC for reasonable costs and attorney's fees incurred by SCC. No waiver by SCC of any breach of Purchaser shall be effective unless in writing nor operate as a waiver of any other breach of the same term thereafter. SCC shall not lose any right because it has not exercised it in the past.

**Applicable Law.** This Agreement is made in Michigan and shall be governed by and interpreted according to Michigan law. Any lawsuit arising out of this Agreement or the Goods may be handled by a federal or state court whose district includes Muskegon County, Michigan, and Purchaser consents that such court shall have personal jurisdiction over Purchaser.

**Miscellaneous.** If any provision of this Agreement is found to be invalid or unenforceable under any law, the provision shall be ineffective to that extent and for the duration of the illegality, but the remaining provisions shall be unaffected. Purchaser shall not assign any of its rights nor delegate any of its obligations under this Agreement without prior written of SCC. This Agreement shall be binding upon and inure to the benefit of SCC and Purchaser and each of their legal representatives, successors and assigns.

SCC warrants its products to be free of defects in materials and workmanship under normal use and service for a period of one (1) year from the date of delivery.

This warranty is extended only to the original purchaser for use of the Goods. It does not cover normal wear parts such as plastic tongs, tong holders, tong cables, bag holders, or acrylic dividers.

**General Conditions.** All service labor and/or parts charges are subject to approval by SCC. Contact the Customer Service Department in writing or call 231-798-8888.

All claims must contain the following information: (1) model & serial code number of equipment; (2) the date and place of installation; (3) the name and address of the agency which performed the installation; (4) the date of the equipment failure; and (5) a complete description of the equipment failure and all circumstances relating to that failure.

Once the claim has been determined to be a true warranty claim by SCC's Customer Service Department, the following procedure will be taken: (1) replacement parts will be sent at no charge from SCC on a freight prepaid basis; (2) reimbursement for service labor will be paid if the following conditions have been met— (a) prior approval of service agency was awarded from the Customer Service Department; and (b) an itemized statement of all labor charges incurred is received by the Customer Service Department. The cost of the service labor reimbursement will be based on straight time rates and reasonable time for the repair of the defect.

If problems occur with any compressor, notify SCC's Customer Service Department immediately. Any attempt to repair or alter the unit without prior consent from the Customer Service Department will render any warranty claim null and void. This warranty and protection plan does not apply to any condensing unit or any part thereof which has been subject to accident, negligence, misuse, or abuse, or which has not been operated in accordance with the manufacturer's recommendations or if the serial number of the unit has been altered, defaced, or removed.

**Limit of Liability.** The limit of liability of SCC toward the exchange cost of the original condensing unit, F.O.B. SCC, Norton Shores, MI, of each motor-compressor assembly replaced during the warranty shall not exceed manufacturer's current established wholesaler's exchange price and in no case shall the labor of removing or replacing the motor-compressor or parts thereof be the responsibility of SCC.